



BENHA UNIVERSITY
FACULTY OF ENGINEERING (SHOUBRA)
ELECTRONICS AND COMMUNICATIONS ENGINEERING



ECE 211

Measurements and Instrumentations
(2022 - 2023) 1st term

Lecture 3: Electromechanical Instruments (part1).

Dr. Ahmed Samir

<https://bu.edu.eg/staff/ahmedsaied>

Chapter Outline:

- 1) **Permanent Magnet Moving Coil (PMMC).**
- 2) Galvanometer.
- 3) DC Ammeters
- 4) DC Voltmeters
- 5) Ohmmeters
- 6) AC Voltmeters
- 7) AC Ammeters

3.1 Permanent Magnet Moving Coil (PMMC):

- ▶ Electromechanical instruments are **electrically operated mechanical instruments** used to measure **electrical quantities** (Volt, Ampere, Ohm).
- ▶ A Permanent Magnet Moving Coil (PMMC) is the **basic building block** of all electromechanical instruments: galvanometers, DC ammeters and voltmeters and ohmmeters.

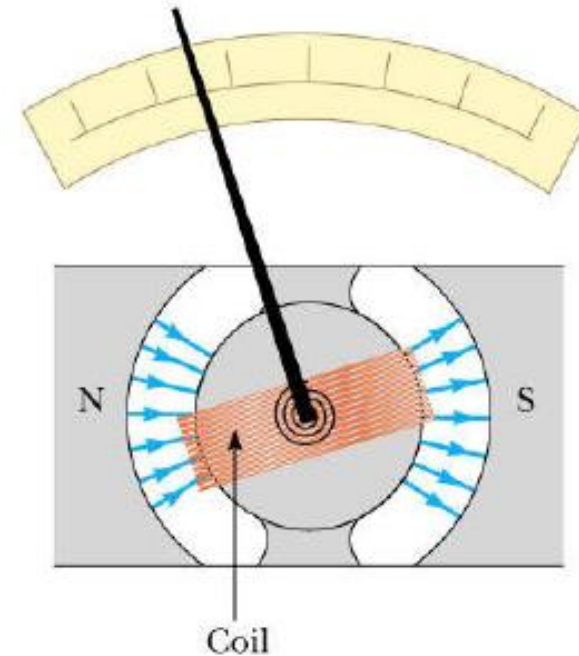

Operation Principle of PMMC:

1. A light weight coil of copper wire suspended in the field of permanent magnet.
2. The current flowing in the wire produces a magnetic field by the coil which interacts with the field from the magnet thereby resulting in partial rotation of the coil.
3. The current flowing in the wire is indicated by the deflection on a calibrated scale through a pointer connected to the coil.

3.1 Permanent Magnet Moving Coil (PMMC):

Deflection Instrument Fundamentals:

To move the pointer in PMMC over the scale, three forces are required:

1. Deflection force.
2. Controlling force.
3. Damping force.

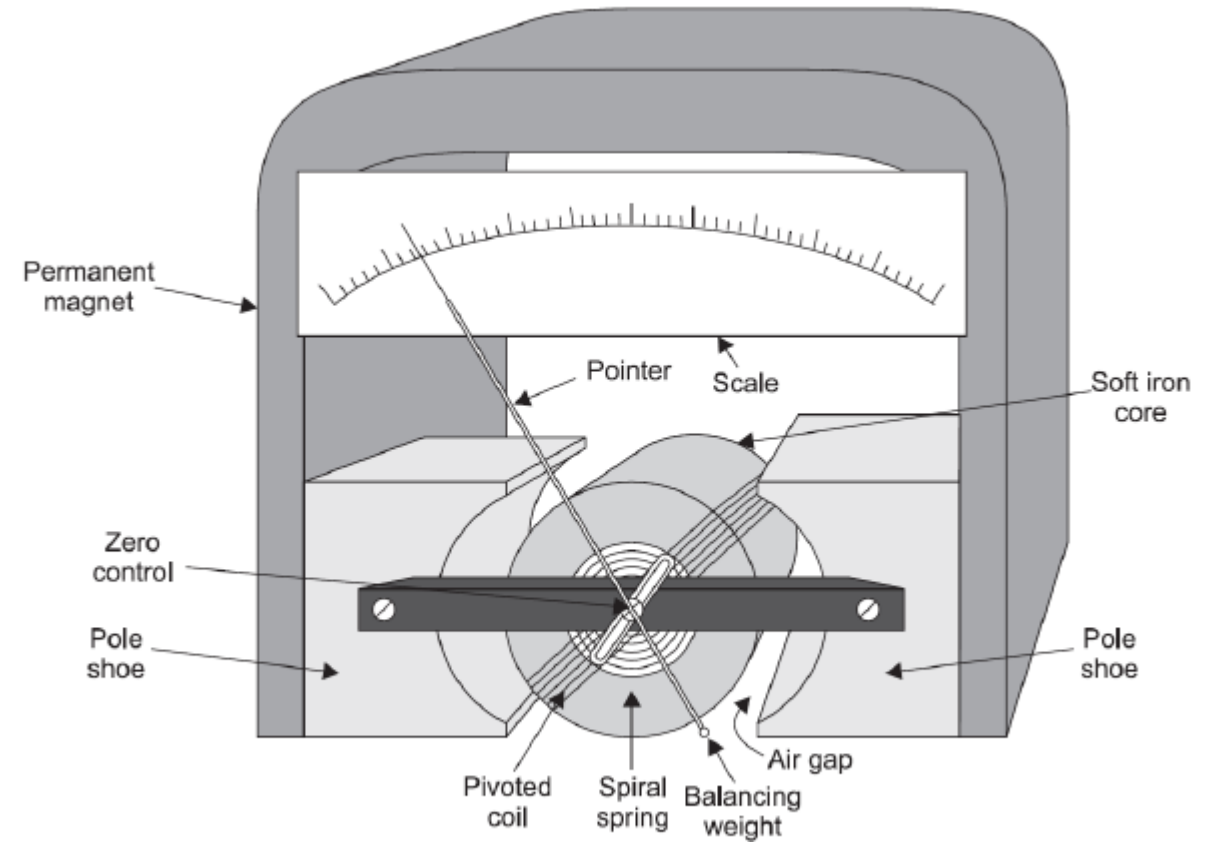

Construction of PMMC

3.1 Permanent Magnet Moving Coil (PMMC): Deflection Instrument Fundamentals:

[1] Deflection force:

- It is the **magnetic force** that causes the **pointer to move** from its zero position when a **current flows**.
- This force is established due to the interaction between **the magnetic field from the current flow** in the coil and **the field from the permanent magnet**.

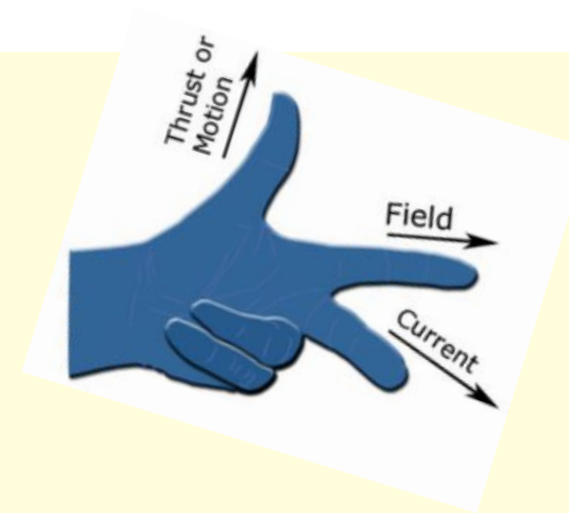
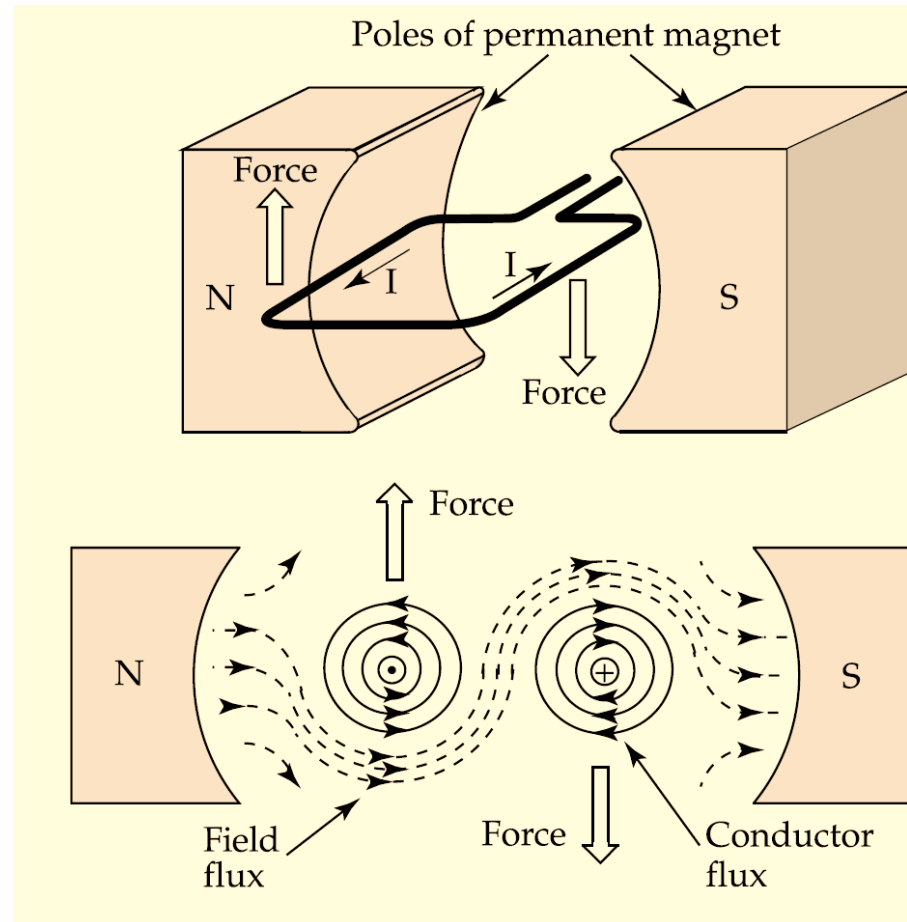

Figure 3-1 The deflecting force in a PMMC instrument is produced by the current in the moving coil. This sets up a magnet flux which interacts with the flux from the poles of the permanent magnet.

3.1 Permanent Magnet Moving Coil (PMMC): Deflection Instrument Fundamentals:

[2] Controlling force:

- The controlling force in the PMMC instrument is provided by **spiral springs**. The springs **retain** the **coil and pointer** at their **zero position** when no current is flowing.
- The **coil and pointer stop** rotating when the **controlling force becomes equal to the deflecting force**.
- The **spring material** must be nonmagnetic to avoid any **magnetic field** influence on the controlling force.
- The **springs are also used** to **make electrical Connection to the coil**, they must have a **low resistance**. Phosphor bronze is the material usually employed.

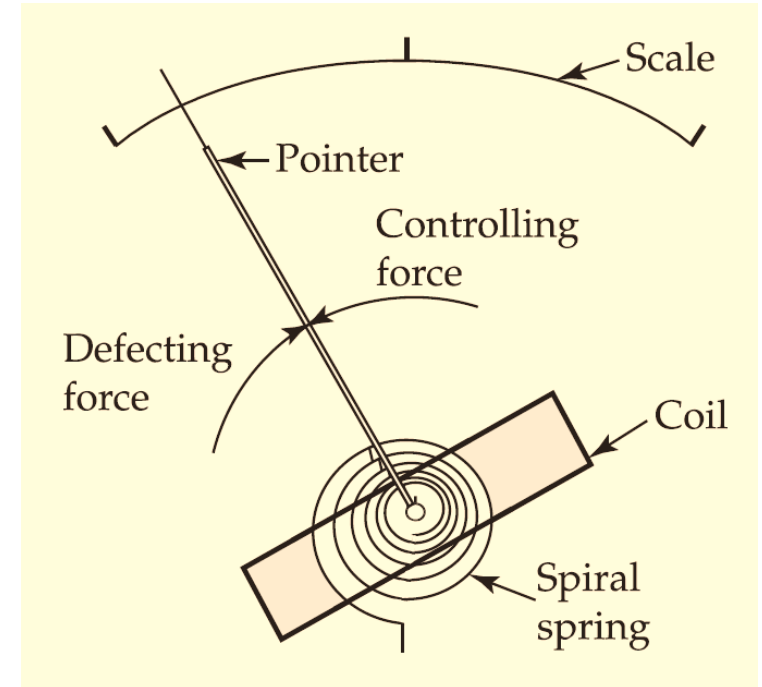
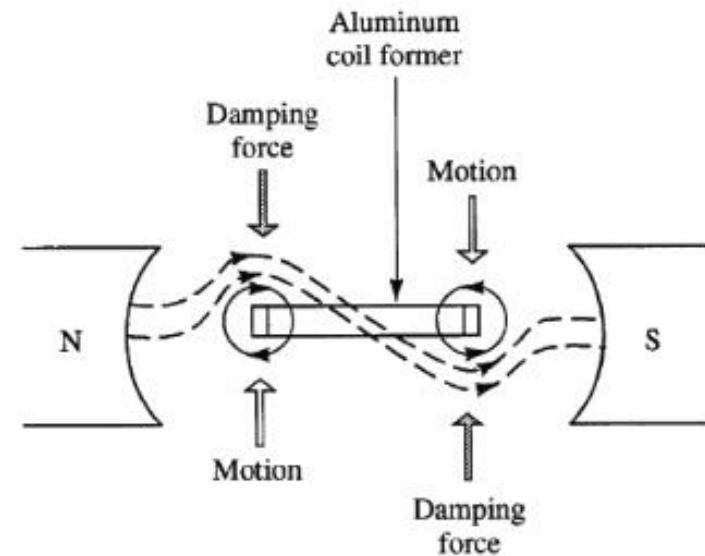
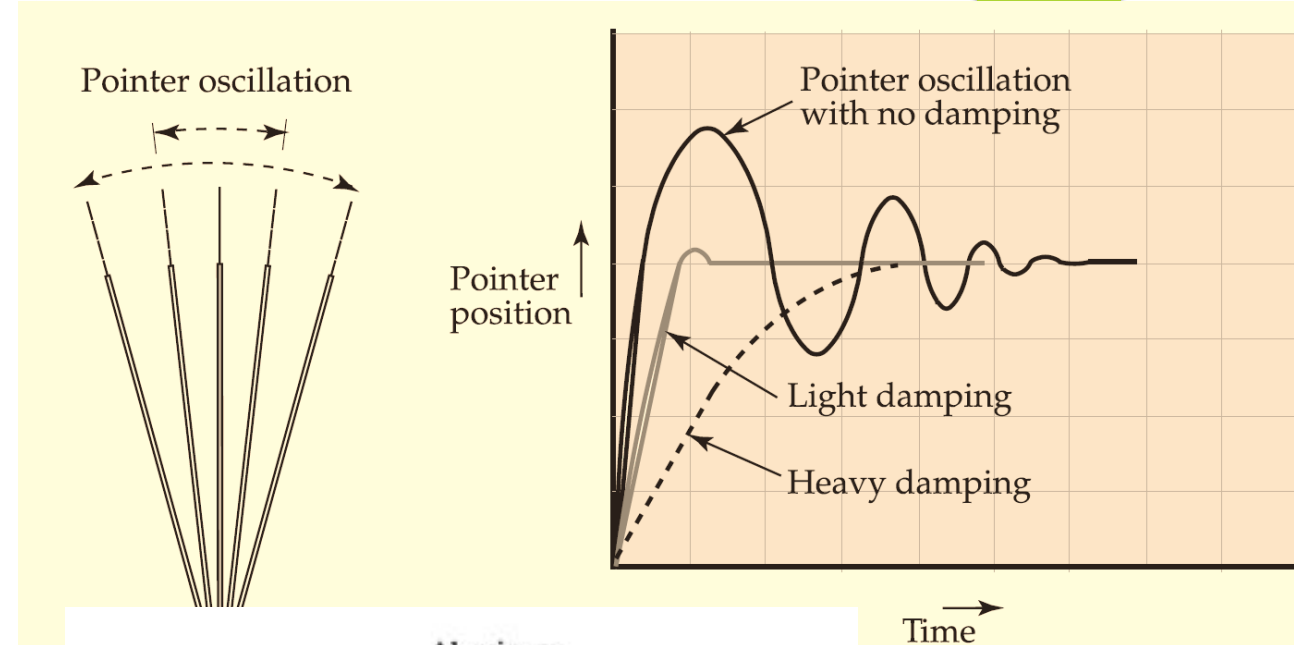

Figure 3-2 The controlling force in a PMMC instrument is provided by spiral springs. The two forces are equal when the pointer is stationary.

3.1 Permanent Magnet Moving Coil (PMMC): Deflection Instrument Fundamentals:

[3] Damping force:

- A damping force is required to **minimize (or damp out) the pointer oscillations** that could occur before stopping at a certain reading.
- This damping is applied by the **Eddy Current** established in the aluminum frame of the coil.
- Eddy currents induced in the coil former set up a magnetic flux that **opposes the coil motion**, thus **damping the oscillations** of the coil and the pointer.
- This force is provided only **when the coil is moving**.



3.1 Permanent Magnet Moving Coil (PMMC):

Construction of PMMC:

Zero Control:

the zero-position control can be **adjusted to calibrate** the coil and pointer position when no coil current is flowing.

Counter weight:

It provides correct **mechanical balance** of the moving pointer so that there is **no gravitational effect** on the accuracy of the instrument.

PMMC is Polarized:

The current in the coil of a PMMC instrument must flow in one particular direction to cause the pointer to move (positively) from the zero position over the scale.

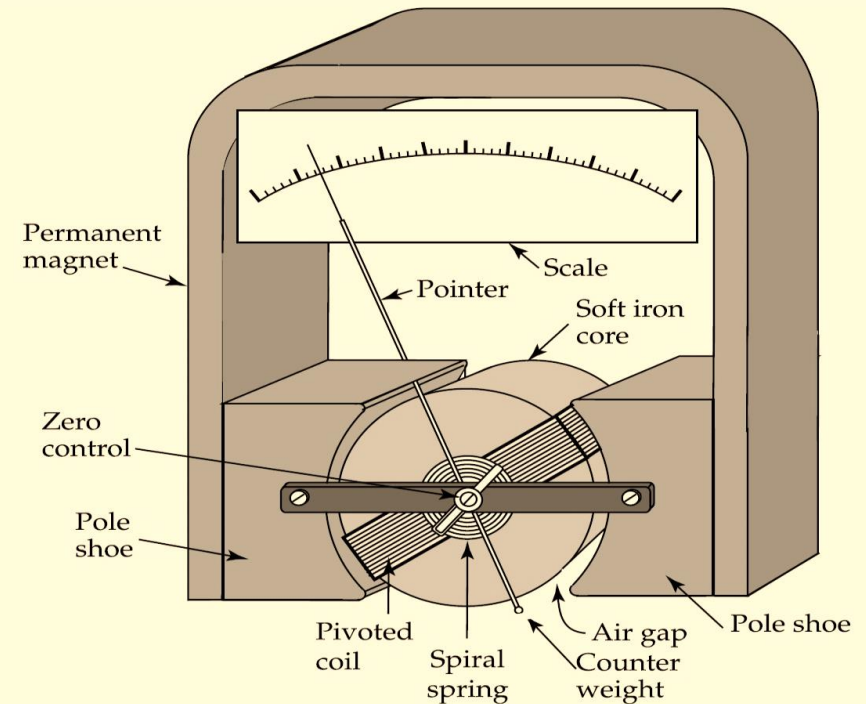

Figure 3-6 A typical PMMC instrument is constructed of a horseshoe magnet, soft-iron pole shoes, a soft-iron core, and a suspended coil that moves in the air gap between the soft-iron core and the pole shoes.

3.1 Permanent Magnet Moving Coil (PMMC):

Torque equation and scale

- ▶ When a current I flows through a one-turn coil situated in a magnetic field, a force F is exerted on **each side** of the coil:

$$F = BIL \text{ newtons}$$

Where B is the magnetic flux density in tesla, I is the current in amperes, and L is the length of the coil in meters

Since for a coil of N turns for two sides

$$F = 2BILN \text{ newtons}$$

Deflecting torque:

$$T_D = 2BILNr \text{ N.m}$$

$$T_D = BILN(2r) \text{ N.m} \implies T_D = BILND \text{ N.m}$$

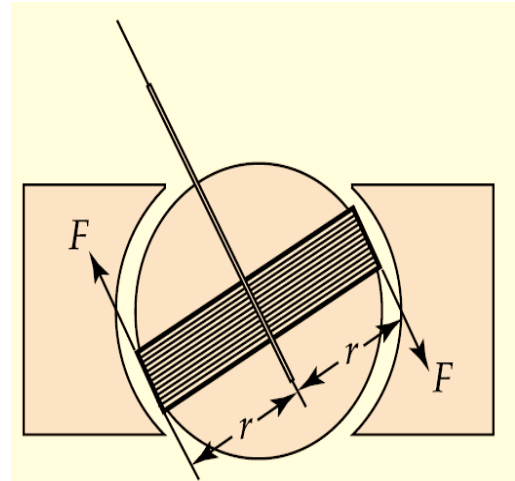

(a) Force F acts on each side of the coil

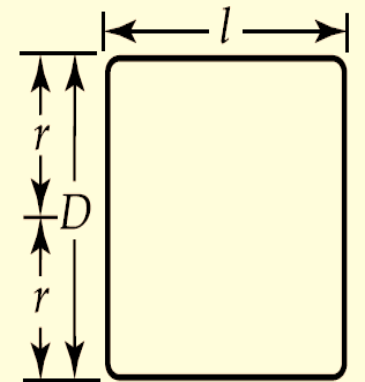
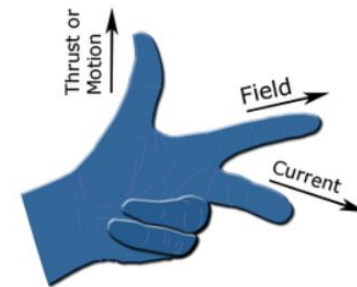

(b) Area enclosed by the coil

3.1 Permanent Magnet Moving Coil (PMMC):

Torque equation and scale (Cont.)

10

- ▶ The **controlling torque** exerted by the spiral springs is directly proportional to the **deformation of the springs**. Thus, the controlling torque is proportional to the actual **angle of deflection** of the pointer:

$$T_c = K\theta \quad N.m \quad \text{Where } K \text{ is a constant}$$

For a given deflection, the controlling and deflecting torques are equal:

The pointer stops when $T_d = T_c$:

$$K\theta = BILND$$

All quantities are constant except θ and I

- ✓ Then, the deflection angle is

$$\theta = CI \quad \text{Where } C \text{ is a constant}$$

3.1 Permanent Magnet Moving Coil (PMMC):

Torque equation and scale (Cont.)

11

$$\theta = CI$$

This equation shows that the pointer deflection is always proportional to the coil current.

Consequently, the scale of the instrument is **linear, or uniformly divided**; that is, if 1 mA produces a 1 cm movement of the pointer from zero, 2 mA produces a 2 cm movement, and so on.

The pointer deflection is always proportional to the coil current and the scale is linear.

3.1 Permanent Magnet Moving Coil (PMMC): Torque equation and scale (Cont.)

► Example 3.1 :

A PMMC instrument with a 100-turn coil has a magnetic flux density in its air gaps of $B = 0.2$ T. The coil dimensions are $D = 1$ cm and $l = 1.5$ cm. Calculate the torque on the coil for a current of 1 mA.

Solution

Equation 3-1,

$$T_D = B l I N D$$

$$= 0.2 \text{ T} \times 1.5 \times 10^{-2} \times 1 \text{ mA} \times 100 \times 1 \times 10^{-2}$$

$$= 3 \times 10^{-6} \text{ N} \cdot \text{m}$$

Chapter Outline:

- 1) Permanent Magnet Moving Coil (PMMC).
- 2) **Galvanometer.**
- 3) DC Ammeters
- 4) DC Voltmeters
- 5) Ohmmeters
- 6) AC Voltmeters
- 7) AC Ammeters

3.2 Galvanometer:

- A galvanometer is essentially a PMMC instrument designed to be **sensitive to extremely low currents** (microamperes).
- Its scale is a **center-zero scale**. The pointer can be deflected to either **right or left** of zero, depending on the direction of current through the moving coil.
- Galvanometers are often employed to detect zero **current or voltage** in a circuit rather than to measure the actual level of current or voltage.

Protection of Galvanometer:

A galvanometer must be protected from the excessive current flow. Protection is provided by an **adjustable resistance** connected in shunt with the instrument to limit the input current.

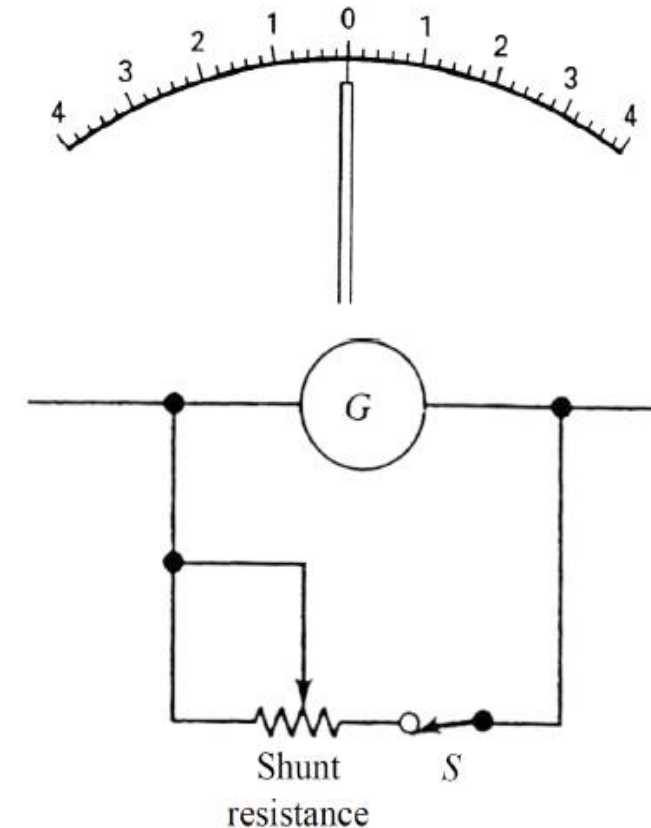

3.2 Galvanometer (Cont.)

- The weight of the **pointer** can create a problem. This is solved in many instruments by mounting a **small mirror** on the moving coil instead of a **pointer**. The mirror reflects a beam of light on to a scale, as illustrated in the figure.
- So, **light-beam galvanometers** sensitive to much lower current levels **than pointer instruments**.

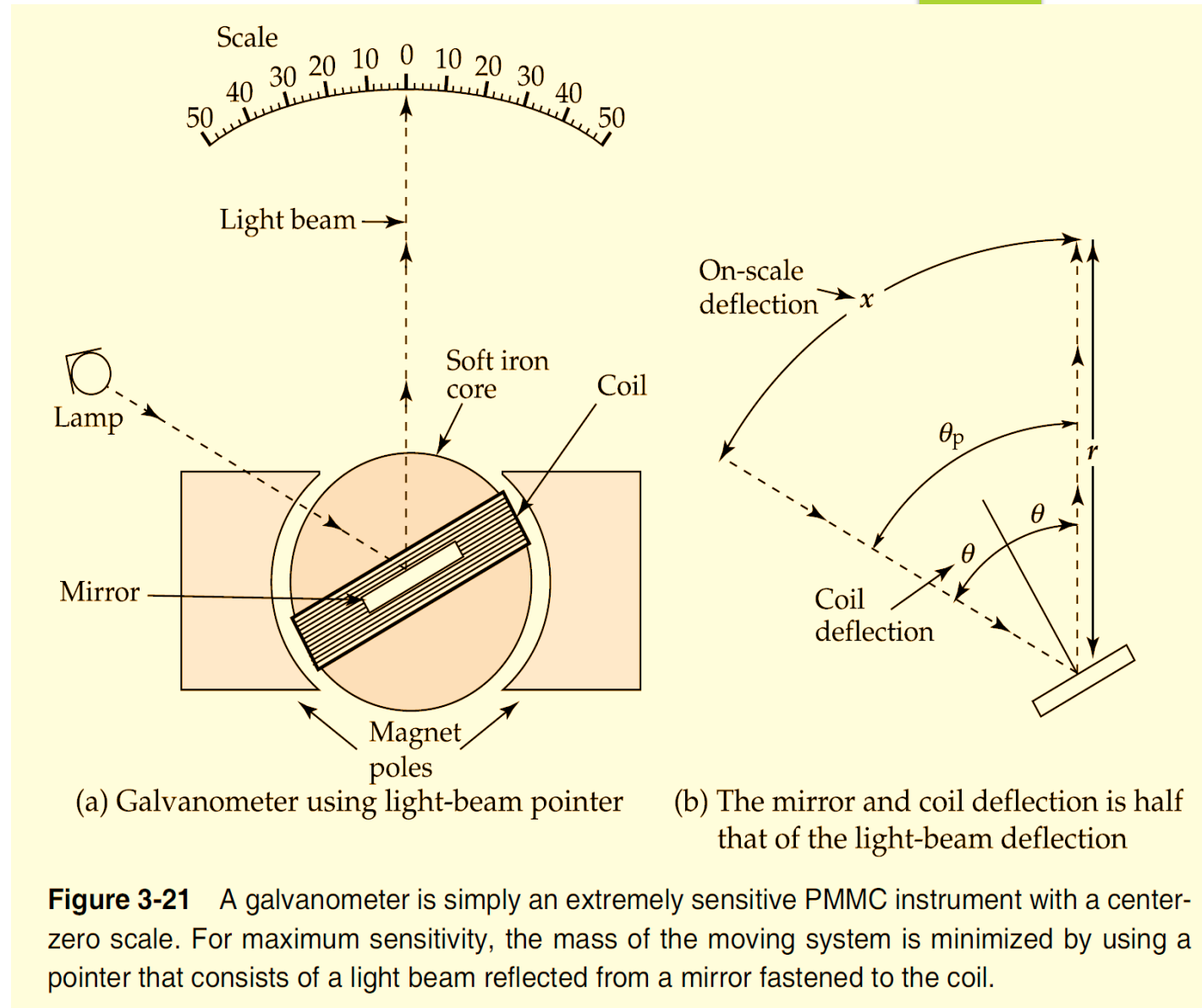



3.2 Galvanometer (Cont.)

There are two types of **sensitivity**:

1. Galvanometer **voltage sensitivity** is often expressed for a given value of **critical damping resistance**. This is usually stated in **microvolts per millimeter**.
2. A **megohm sensitivity**: this is the value of **resistance** that must be connected in series with the instrument to **restrict the deflection** to one scale division **when a potential difference of 1 V** is applied across its terminals.

2.3 Galvanometer (Cont.)

Example 3.2:

A galvanometer has a current sensitivity of $1 \mu\text{A}/\text{mm}$ and a critical damping resistance of $1 \text{ k}\Omega$. Calculate (a) the voltage sensitivity and (b) the megohm sensitivity.

Solution

$$\begin{aligned}\text{Voltage sensitivity} &= 1 \text{ k}\Omega \times 1 \mu\text{A}/\text{mm} \\ &= 1 \text{ mV}/\text{mm}\end{aligned}$$

For a voltage sensitivity of 1 V/mm,

$$\text{megohm sensitivity} = \frac{1 \text{ V}/\text{mm}}{1 \mu\text{A}/\text{mm}} = 1 \text{ M}\Omega$$



END OF LECTURE

BEST WISHES